





## Crankshaft Front Seal

### Special Tool(s)

 ST2197-A	Installer, Crankshaft Front Oil Seal 303-635
 ST1287-A	Installer, Crankshaft Vibration Damper 303-102 (T74P-6316-B)
 ST1328-A	Installer, Front Cover Oil Seal 303-335 (T88T-6701-A)
 ST1288-A	Remover, Crankshaft Front Oil Seal 303-107 (T74P-6700-A)

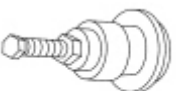
### Material

Item	Specification
Motorcraft® SAE 5W-20 Premium Synthetic Blend Motor Oil XO-5W20-QSP (US); Motorcraft® SAE 5W-20 Super Premium Motor Oil CXO-5W20-LSP12 (Canada); or equivalent	WSS-M2C930-A

### Removal

1. Remove the crankshaft pulley. For additional information, refer to [Crankshaft Pulley](#) in this section.
2. Using the Crankshaft Front Oil Seal Remover, remove the crankshaft front seal.

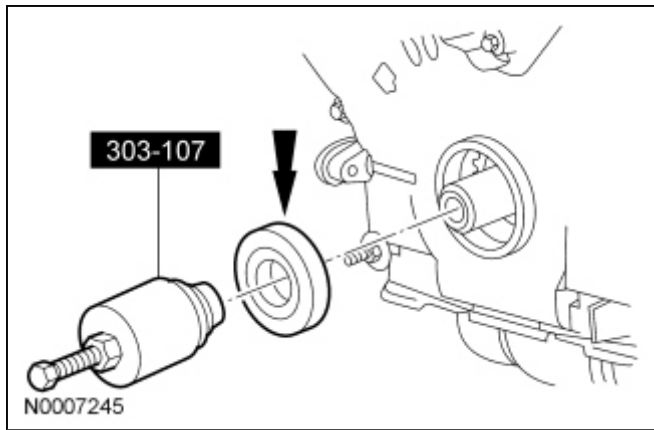

## Installation

1. Lubricate the engine front cover and the crankshaft front seal inner lip with clean engine oil.

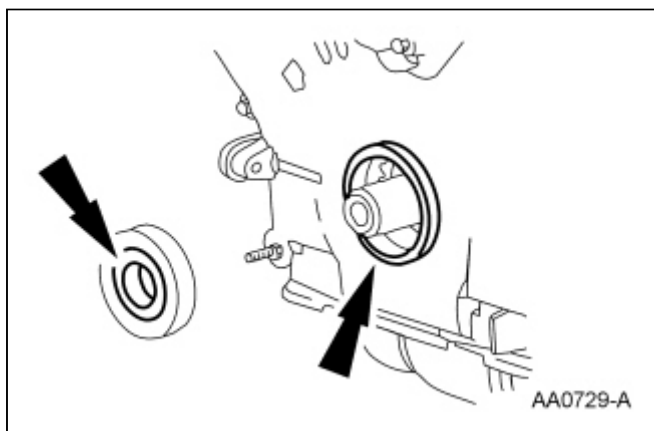

2. Using the Crankshaft Vibration Damper Installer, Front Cover Oil Seal Installer and the Crankshaft Front Oil Seal Installer, install the crankshaft front seal.

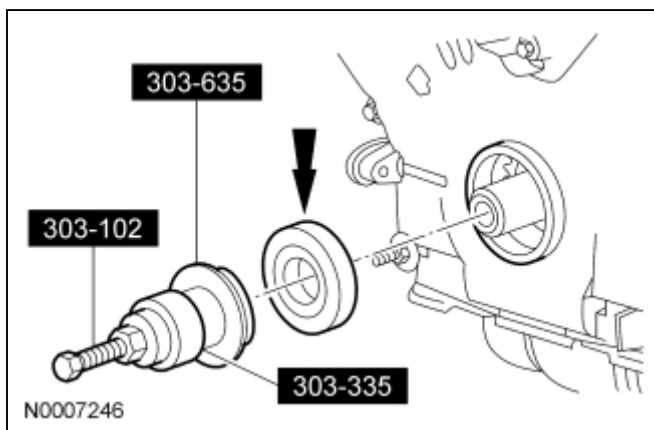

3. Install the crankshaft pulley. For additional information, refer to [Crankshaft Pulley](#) in this section.
-

